

ARTICLE 230

SERVICES

Introduction to Article 230—Services

This article covers the installation requirements for service conductors and service equipment. The requirements for service conductors differ from those for other conductors. For one thing, service conductors for one building can't pass through the interior of another building or structure [230.3], and you apply different rules depending on whether a service conductor is inside or outside a building. When are they "outside" as opposed to "inside?" The answer may seem obvious, but 230.6 should be consulted before making this decision.

Let's review the following definitions in Article 100 to understand when the requirements of Article 230 apply:

- **Service Point.** The point of connection between the serving utility and the premises wiring.
- **Service Conductors.** The conductors from the service point to the service disconnecting means. Service-entrance conductors can either be overhead or underground.
- **Service Equipment.** The necessary equipment, usually consisting of circuit breakers or switches and fuses and their accessories, connected to the load end of service conductors at a building or other structure, and intended to constitute the main control and cutoff of the electrical supply. Service equipment doesn't include individual meter socket enclosures [230.66].

After reviewing these definitions, you should understand that service conductors originate at the serving utility (service point) and terminate on the line side of the service disconnecting means. Conductors and equipment on the load side of service equipment are considered feeder conductors or branch circuits, and must be installed in accordance with Articles 210 and 215. They must also comply with Article 225 if they're outside branch circuits and feeders, such as the supply to a building. Feeder conductors include: [Figure 230-1](#) and [Figure 230-2](#)

- Secondary conductors from customer-owned transformers,
- Conductors from generators, UPS systems, or PV systems, and
- Conductors to remote buildings

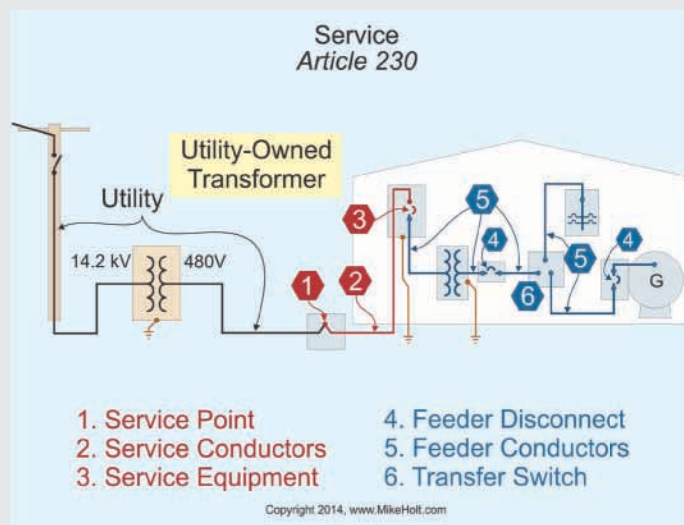

Figure 230-1

Article 230 consists of seven parts:

- Part I. General
- Part II. Overhead Service Conductors
- Part III. Underground Service Conductors
- Part IV. Service-Entrance Conductors
- Part V. Service Equipment
- Part VI. Disconnecting Means
- Part VIII. Overcurrent Protection

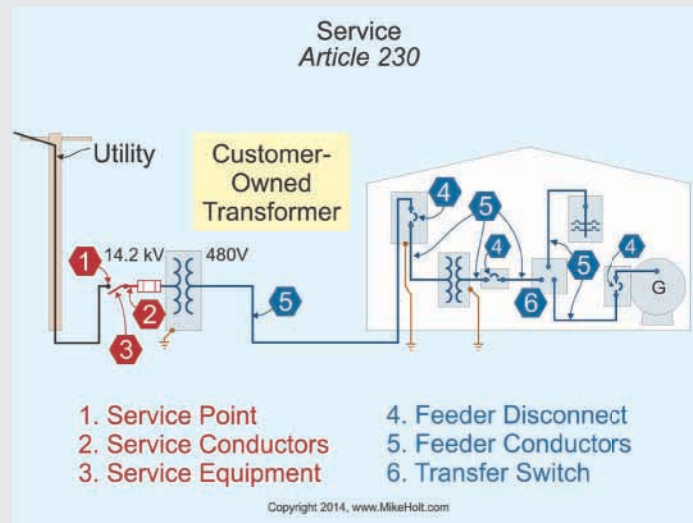

Figure 230–2

Part VI. Service Equipment—Disconnecting Means

Essential Rule 19

230.71 Number of Disconnects

(A) Maximum. There must be no more than six service disconnects for each service permitted by 230.2, or each set of service-entrance conductors permitted by 230.40 Ex 1, 3, 4, or 5. [Figure 230–3](#) and [Figure 230–4](#)

The service disconnecting means can consist of up to six switches or six circuit breakers mounted in a single enclosure, in a group of separate enclosures, or in or on a switchboard, or in switchgear.

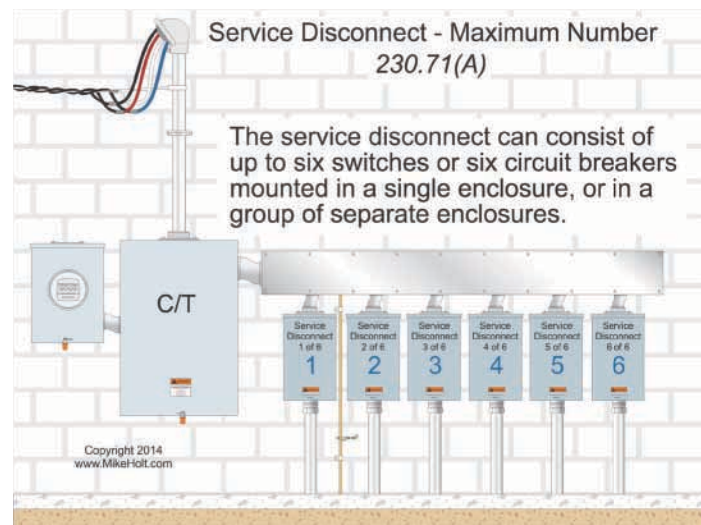

Figure 230–3



CAUTION: *The rule is six disconnecting means for each service, not for each building. If the building has two services, then there can be a total of 12 service disconnects (six disconnects per service).* [Figure 230–5](#)

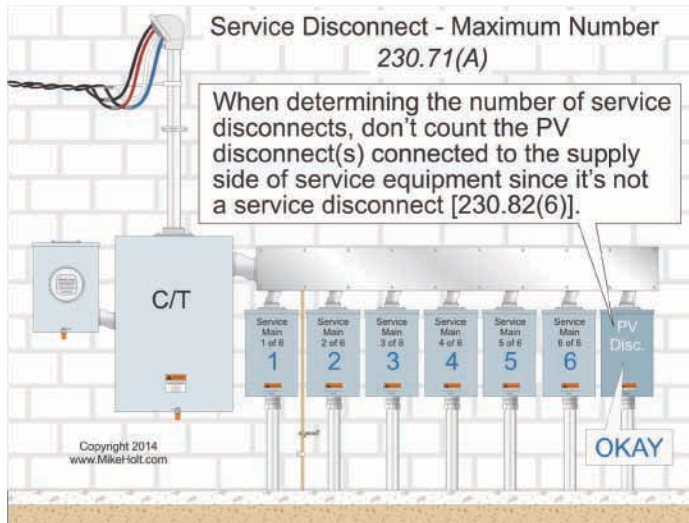

Figure 230-4

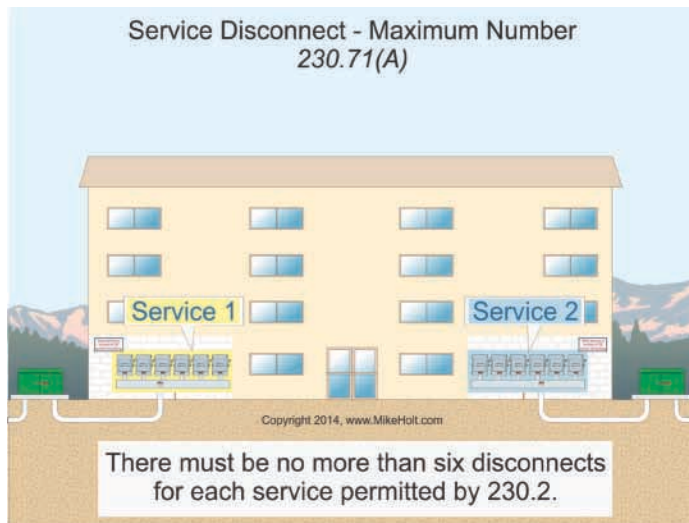

Figure 230-5

Essential Rule 20

230.72 Grouping of Disconnects

(A) Two to Six Disconnects. The service disconnecting means for each service must be grouped.

(B) Additional Service Disconnecting Means. To minimize the possibility of simultaneous interruption of power, the disconnecting means for fire pumps [Article 695], emergency [Article 700], legally required standby [Article 701], or optional standby [Article 702] systems must be located remote from the one to six service disconnects for normal service.

Author's Comment:

- Because emergency systems are just as important as fire pumps and standby systems, they need to have the same safety precautions to prevent unintended interruption of the supply of electricity.

(C) Access to Occupants. In a multiple-occupancy building, each occupant must have access to their service disconnecting means.

Ex: In multiple-occupancy buildings where electrical maintenance is provided by continuous building management, the service disconnecting means can be accessible only to building management personnel.